

Model DSC1400 Fiber Optic Dynamic Signal Conditioner

DavidsonSensors™ provide the safest, most reliable and cost-effective instrumentation for harsh industrial applications.

This product data sheet describes Model DSC1400 dynamic high frequency signal conditioner. This universal signal conditioner may be operated with any combination of Davidson dynamic transducers including: pressure, load, vibration, acceleration, and position.

This unit will interrogate up to sixteen sensors and is packaged in a 19" subrack. The standard output options are +/-5 Volt analog or digital over Ethernet.

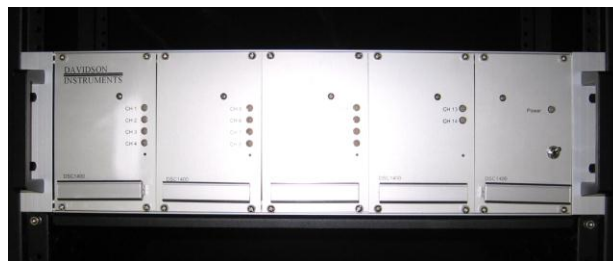

**Dynamic High Frequency Response
Signal Conditioner**

Functional Specifications

Channels

14 - 16 Channels

Input Power

120/240 VAC; 50-60Hz; 10 Watts

Output Signal

+/- 4.5 Volt Analog
Digital over Ethernet

Temperature Limits

32°F to 120°F

Humidity Limits

0 to 100% relative humidity

Transmission Range

1000 feet

Displacement Range

14,000 to 22,000 nm

Fiber Specification

62.5/125 Multimode

Physical Specifications

Size

19" Rackmount x 3U high x 12" deep

Weight

15 lbs

Signal Output Connectors

External BNC Connectors
Ethernet

Fiber Optic Sensor Connectors

External ST Bulkhead

Performance Specifications

Displacement Accuracy

2% of Full Scale

Frequency Response

2 Hz to 10 kHz (+/- 0.5 dB)

Theory of Operation

A fiber optic signal conditioner is the equivalent of a transmitter or charge amplifier in conventional electronic sensing systems. During operation, the signal conditioner sends a continuous stream of light to each of the transducers. The light signal received from each transducer is focused through a lens and transmitted through a Fizeau interferometer (optical wedge) and onto a CCD array. The Fizeau interferometer acts as an optical cross-correlator and instantly converts the modulated light into a cross-correlated light signal that is projected onto a linear CCD with more than one hundred pixels. The CCD captures the light waveform which is unique for any gap in the transducer. The light signal is interrogated at up to 80 kHz and changes in the transducer gap in the range of nanometers are measured.

Through rigorous calibration done at the factory, the calibration constants are known for each transducer and loaded into the microprocessor. The microprocessor converts the change in gap into the proper engineering units, (i.e. changes in psig, inches of water, °F), for the transducer. The result is unprecedented measurement accuracy and frequency response in harsh industrial environments.

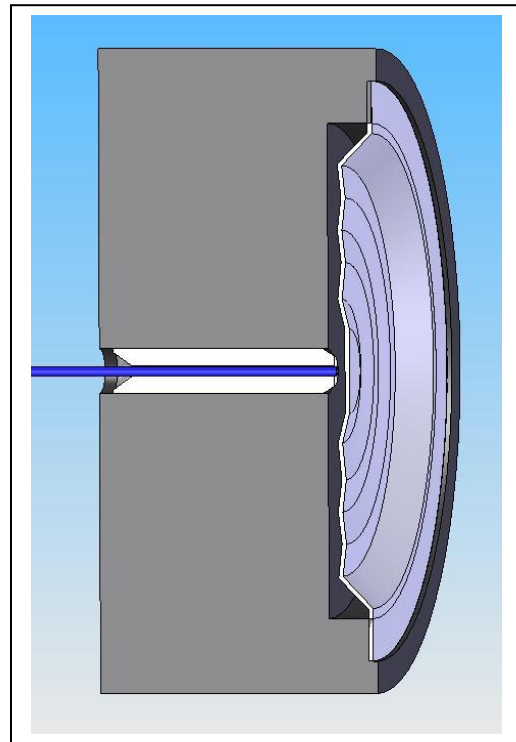

Fiber Optic Pressure Sensing Diaphragm

Fiber Optic Sensing Advantages

Fiber optic sensing offers a number of advantages for measurement in harsh industrial environments. DavidsonSensors™ are intrinsically-safe, immune to electromagnetic interference, and suitable for continuous use at temperatures up to 1000°F.

Although fiber optic sensing systems can be used effectively even in benign environments, Davidson fiber optic sensing systems offer significant technical advantages when used in the following environments:

- **Hot, Corrosive Environments**
- **Explosion Hazardous Areas**
- **High EMI Areas**

Fiber optic sensing systems eliminate or mitigate many of the following common problems:

- **Failure and Drift due to Hydrogen Permeation**
- **Drift due to Fill-Fluid Leaks**
- **Failure due to Lightning**
- **Problems due to Ground Potential**
- **Noise due to EMI/RFI**
- **Costs of Nitrogen Purge Systems**

Testing and Calibration

Calibration is performed over the entire displacement range at 72° F.

Documentation

A user’s manual is included with each unit.

Tagging

Stainless steel tags will be permanently attached to each signal conditioner upon request.

Other Applications

For information about other Davidson products, see www.davidson-instruments.com

Guide to Configuring a Fiber Optic Sensing System

For information to assist you in planning a fiber optic sensing system, see www.davidson-instruments.com

Ordering Data

Model Number	DSC1400	
Channels	14	14 Channels
	16	16 Channels
Fiber Optic Connector Type	1	ST
	2	Other
Other Specifications*	0	No
	1	Yes

* Tagging, documentation, other instructions etc.

Ordering Data Worksheet

Unit Number	Model Number	Number of Channels	Fiber Optic Connector Type	Other Specifications
1	DSC1400			
2	DSC1400			
3	DSC1400			
4	DSC1400			
5	DSC1400			
6	DSC1400			

Standard Model is DSC1400-16-ST-0

Davidson Instruments, Inc.
 8301 New Trails Drive
 The Woodlands, TX 77381 USA

 Telephone: 281-362-4900
 Fax: 281-362-4933
 sales@ davidson-instruments.com
 www.davidson-instruments.com

 © 2011 Davidson Instruments, Inc.

U.S. Patents 5,202,939; 5,392,117; U.S. Patent Pending