

Model DSU1250 Fiber Optic Absolute Signal Conditioner

DavidsonSensors™ provide the safest, most reliable and cost-effective instrumentation for harsh industrial applications.

This product data sheet describes Model DSU1250 absolute high resolution signal conditioner. This universal signal conditioner is packaged in a 19" rackmount enclosure and is limited to controlled environmental conditions. It may be multiplexed with any combination of Davidson static transducers including: pressure, temperature, load, and position.

This unit may be configured with up to thirty-two (32) channels and may be ordered with a variety of outputs to interface with supervisory control systems.



Absolute High Resolution Signal Conditioner

Functional Specifications

Channels

Up to 32 Channels in 8 Channel Modules

Input Power

120/240 VAC; 50-60Hz; 40 Watts

Output Signal

RS-232/RS-485 Modbus
4-20 mA

Temperature Limits

60°F to 90°F

Humidity Limits

0 to 100% relative humidity

Transmission Range

1000 feet

Displacement Range

6,000 to 19,500 nm

Fiber Specification

62.5/125 Multimode

Physical Specifications

Size

12" X 10" X 6"

Weight

15 lbs

Enclosure Class

NEMA 4

Power/Communications Connectors

Internal Terminal Block with Conduit Interface

Fiber Optic Sensor Connectors

External ST Bulkhead

Performance Specifications

Displacement Accuracy

0.01% of Full Scale

Update Rate

1Hz (1 channel per second)

Theory of Operation

A fiber optic signal conditioner is the equivalent of a transmitter in conventional electronic sensing systems. During operation, the signal conditioner sends a pulse of light in sequence to each of the interferometric transducers. The light signal received from each transducer is focused through a lens and transmitted through a Fizeau interferometer (optical wedge) and onto a CCD array. The Fizeau interferometer acts as an optical cross-correlator and instantly converts the modulated light into a cross-correlated signal that is projected onto a linear CCD with thousands of pixels. The effect of the cross-correlation is that the peak of the signal occurs at that location on the CCD where the optical length of the interferometric gap in the sensor matches precisely with the optical length of the interferometric gap in the Fizeau interferometer. Each pixel in the CCD is calibrated to a precise optical thickness in the Fizeau interferometer.

The CCD converts the light signal into an electronic signal that is processed by a microprocessor. The microprocessor in the signal conditioner converts the peak signal into a known length of gap. Through rigorous calibration done at the factory, the calibration constants are known for each transducer and loaded into the microprocessor. The microprocessor converts the known gap into the proper engineering units, (i.e. psig, inches of water, °F), for the transducer.

Since all of Davidson fiber optic sensors are based on the same interferometric sensing technology, different measurands can be multiplexed and processed by a single signal conditioner. Multiplexing a variety of sensors with a single signal conditioner allows multivariate signal processing, error correction, etc. The result is unprecedented measurement accuracy in harsh industrial environments. Once the measurement is corrected and converted into the appropriate engineering units, the signal conditioner then transmits the measured result to the process control system based on the specified analog or digital protocol, i.e. 4-20mA analog or RS-485 Modbus digital protocol. Ideally, a multi-channel signal conditioner is located in a control room environment and interrogates multiple transducers. The signal conditioner can be packaged in a 19" rackmount, NEMA enclosure, or explosion-proof container.

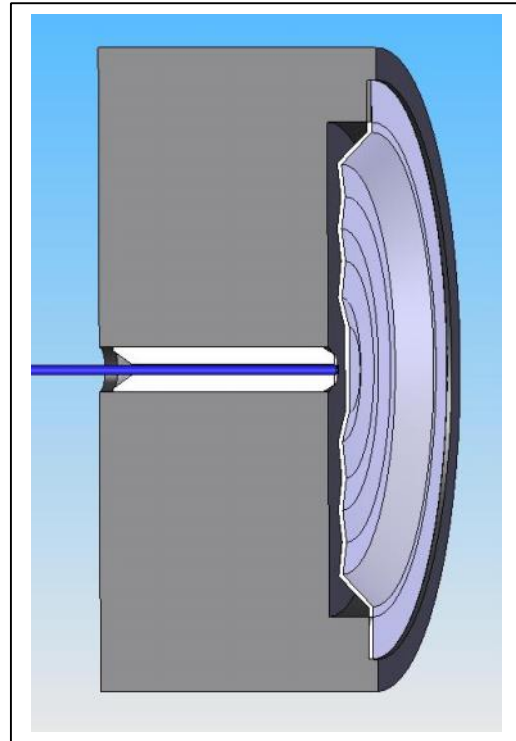

Fiber Optic Pressure Sensing Diaphragm

Fiber Optic Sensing Advantages

Fiber optic sensing offers a number of advantages for measurement in harsh industrial environments. DavidsonSensors™ are intrinsically-safe, immune to electromagnetic interference, and suitable for continuous use at temperatures up to 1000°F.

Although fiber optic sensing systems can be used effectively even in benign environments, Davidson fiber optic sensing systems offer significant technical advantages when used in the following environments:

- **Hot, Corrosive Environments**
- **Explosion Hazardous Areas**
- **High EMI Areas**

Fiber optic sensing systems eliminate or mitigate many of the following common problems:

- **Failure and Drift due to Hydrogen Permeation**
- **Drift due to Fill-Fluid Leaks**
- **Failure due to Lightning**
- **Problems due to Ground Potential**
- **Noise due to EMI/RFI**
- **Costs of Nitrogen Purge Systems**

Testing and Calibration

Calibration is performed over the entire displacement range at 72° F.

Documentation

A user’s manual is included with each unit.

Tagging

Stainless steel tags will be permanently attached to each signal conditioner upon request.

Other Applications

For information about other Davidson products, see www.davidson-instruments.com

Guide to Configuring a Fiber Optic Sensing System

For information to assist you in planning a fiber optic sensing system, see www.davidson-instruments.com

Ordering Data

Model Number	DSU1250	
Number of Channels	A	8
	B	16
	C	24
	D	32
Signal Output	R	RS-485 Modbus
	M	4-20 mA
Self Diagnostics	0	No
	1	Yes
Other Specifications*	0	No
	1	Yes

* Tagging, documentation, other instructions etc.

Ordering Data Worksheet

Unit Number	Model Number	Number of Channels	Signal Output	Self Diagnostics	Other Specifications
1	DSU1250				
2	DSU1250				
3	DSU1250				
4	DSU1250				
5	DSU1250				
6	DSU1250				

U.S. Patents 5,202,939; 5,392,117; U.S. Patent Pending

Davidson Instruments, Inc.
 8301 New Trails Drive
 The Woodlands, TX 77381 USA

 Telephone: 281-362-4900
 Fax: 281-362-4933
 sales@davidson-instruments.com
 www.davidson-instruments.com

 © 2006 Davidson Instruments, Inc.